

CONNECTORS

Compression Connectors

Copper Soldering Lugs

S Series



SPECIFICATIONS

- Temperature Rating: 90 °C.
- Voltage: 600V.

FEATURES

- Made of pure electrolytic copper single hole.
- Side formed with round ends.
- All lugs marked with ampere rating.

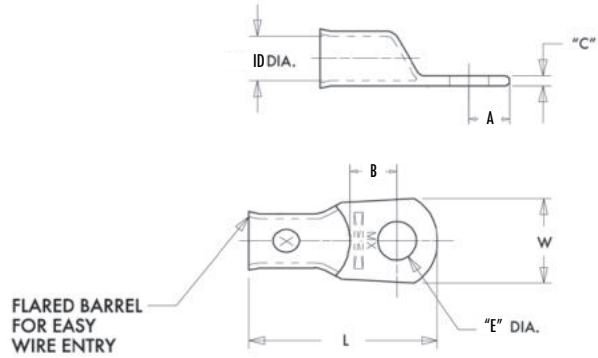

CAT. NO.	WIRE SIZE	AMPERES	LENGTH (L) (IN.)	WIDTH (W) (IN.)	BARREL I.D.	HOLE DIAMETER (E) (IN.)	TANG THICKNESS (C) (IN.)	TANG LENGTH (A) (IN.)	END OF CONN. TO CTR. OF 1ST HOLE (A) (IN.)	STD CTN. QTY.
S-1	10	25	0.847	0.267	0.192	0.160	0.057	0.464	0.238	100
S-2	8	30-35	1.313	0.594	0.270	0.278	0.070	0.720	0.342	100
S-3	6	45-50	1.180	0.456	0.315	0.200	0.068	0.555	0.275	100
S-4	4	60-70	1.500	0.531	0.386	0.278	0.080	0.685	0.310	100
S-5	2	90	1.625	0.625	0.427	0.340	0.095	0.730	0.350	50
S-6	1/0	100-125	1.844	0.728	0.493	0.278	0.110	0.840	0.407	50
S-7	2/0	150	2.062	0.824	0.560	0.400	0.110	0.950	0.465	50
S-8	3/0	175	2.156	0.916	0.624	0.400	0.115	0.950	0.520	25
S-9	4/0	200-225	2.344	0.999	0.682	0.400	0.135	1.012	0.510	25
S-10	250	250	2.573	1.187	0.799	0.404	0.140	1.2	0.565	25