

CONNECTORS

Mechanical Connectors

Aluminum, Dual Rated, Dual Range Lugs BS Series



SPECIFICATIONS

- CSA 70142.
- UL Listed Wire Connector.
- UL486A/B Listed. AL9CU.
- Temperature Rating: 90 °C.
- Voltage: 600V max. (2000V ma. per UL486B).

FEATURES

- Set-screw connectors that will accept either one or two wires.
- Made of 6061T-6 aluminum alloy.
- Electro-tin plated for low contact resistance.
- For use with copper or aluminum conductors.

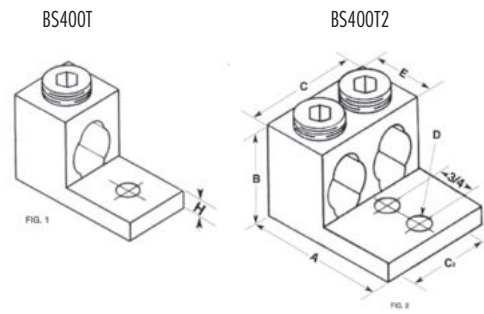

CAT. NO.	FIG. NO.	WIRE RANGE	MAX TORQUE VALUE (IN./LBS.)	HEX WRENCH SIZE (IN.)	MTG. BOLT SIZE (IN.)	LENGTH (A) (IN.)	HEIGHT (B) (IN.)	WIDTH (C) (IN.)	MTG. HOLE DIA. (D) (IN.)	TANG LENGTH (F) (IN.)	TANG THICKNESS (H) (IN.)	STD. CTN. QTY.	
BS400T	1	(1) 600 MCM-4 AWG	500	3/8	⬡	0.562	2.810	1.810	1.380	0.625	.725	0.312	6
BS400T	1	(2) 250 MCM-1/0 AWG	500	3/8	⬡	0.562	2.810	1.810	1.380	0.625	.725	0.312	6
BS400T2	2	(2) 250 MCM-1/0 AWG	500	3/8	⬡	0.250	3.812	2.000	2.468	0.281	.325	0.375	4
BS400T2	2	(4) 250 MCM-1/0 AWG	500	3/8	⬡	0.250	3.812	2.000	2.468	0.281	.325	0.375	4