

# GROUNDING

## Ground Clamps

### Heavy Duty & with 360° Adapters for Rigid Conduit

#### EG Series



#### SPECIFICATIONS

- cULus Listed 467 Grounding & Bonding.
- UL467 Listed, Grounding & Bonding.
- CSA.

#### FEATURES

- Bronze water pipe clamps with bronze adapters.
- Excellent quality yet economical.
- All adapters are interchangeable.
- Assembled with zinc-plated steel screws.
- Hub swings 360° for easy alignment.
- Used to connect rigid conduit and ground conductor to water pipe.

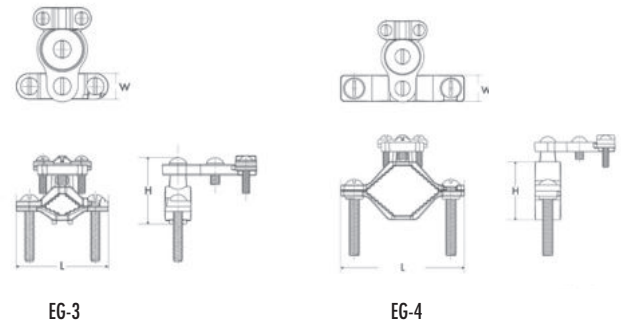
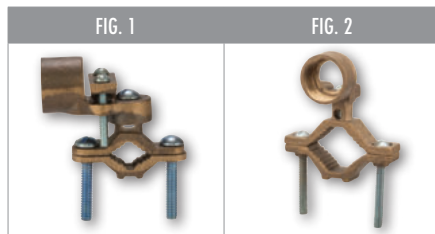

CAT. NO.	FIG. NO.	CERTIFICATION	PIPE SIZE (IPS) (IN.)	GROUND WIRE RANGE (IN.)	CONDUIT HUB SIZE (IN.)	LENGTH (L) (IN.)	WIDTH (W) (IN.)	HEIGHT (H) (IN.)	STD. CTN. QTY.
EG-3	1	cULus	1/2 - 1	10 SOL - 2/0 STR	1/2	2.200	0.585	2.300	20
EG-4	1	UL	1 1/4 - 2	10 SOL - 2/0 STR	1/2	3.588	0.737	3.117	10
EG-5	1	cULus	1/2 - 1	10 SOL - 2/0 STR	1/2	2.208	0.597	2.210	15
EG-6	1	UL	1 1/4 - 2	10 SOL - 2/0 STR	1/2	3.631	0.725	2.696	10
EG-7	1	UL	1/2 - 1	10 SOL - 2/0 STR	3/4	2.298	0.663	2.470	15
EG-8	1	UL	1 1/4 - 2	10 SOL - 2/0 STR	3/4	3.576	0.789	3.841	8
EG-9	1	UL	1/2 - 1	10 SOL - 3/0 STR	1	2.280	0.650	1.900	12
EG-10	2	UL	1 1/4 - 2	10 SOL - 3/0 STR	1	3.587	0.792	4.029	8
EG-15	2	cULus	2 1/2 - 4	10 SOL - 2/0 STR	1/2	6.125	0.972	4.834	6
EG-24	2	UL	2 1/2 - 4	10 SOL - 3/0 STR	1	6.125	0.962	5.158	6



Scan QR code  
for mobile access to  
Grounding drawings.