

RANGE HOODS / WALL-MOUNT

LUNA-CRISTAL

24600-480-S • (30" - 480 CFM)

TECHNICAL SPECIFICATIONS

- Tempered glass and stainless steel finish
- 480 CFM
- Noise level: low speed 0.6 to hi 8.0 sones (high speed)
- 3-speed control
- 2 LED bulbs, 5W, with 2 light levels (incl.)
- 5-layer aluminum filters (incl.)
- 6" round vertical vent exhaust
- Telescopic chimney 19 3/4" (bottom section) - 19 3/4" (top section)
- Optional 30" chimney for ceilings up to 10 feet
- Good for ceilings up to 8 ft 6 in. (For 9' (108") ceilings, the hood can be installed using the sections of chimney provided, as long as it is installed at a distance of at least 31" from the counter.)

DIMENSIONS

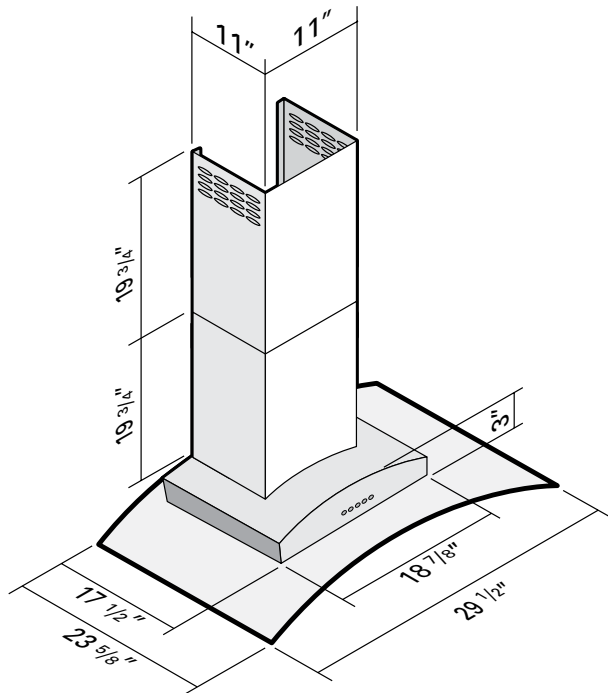

NOTICE TO THE INSTALLER OR PURCHASER

As indicated on the box, the hood should be connected and tested prior to installation; if the hood works properly at that time but a problem arises after installation, the problem is not due to the hood but to improper installation somewhere between the hood and the outside vent.

TYPES OF MALFUNCTION:

- Noise and vibrations from the hood
- The motor makes a screeching sound and seems to be forcing
- The suction power seems to be approximately the same for all settings.

CHECK THE VENT

The most common problem is range hood flaps that fail to open:

- Did you remove the protective adhesive strip on the flaps?
- Did you install the duct too tightly over the flaps, preventing them from opening fully?
- Never use screws to attach the duct to the hood outlet. Use duct tape instead
- To quickly check whether the valves are operating properly, run the hood for 30 second then turn it off. After 2 or 3 seconds, you should hear the two flaps close one after the other.

Note: For more informations see section "Range hoods - Noise and vibrations issues" on our web site.

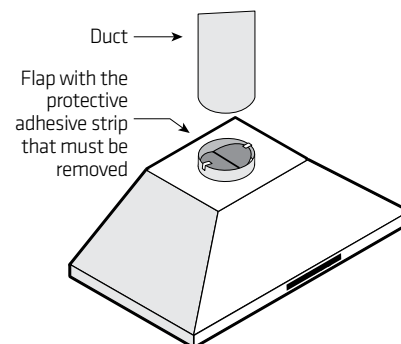

4300 Grande-Allée Blvd, Boisbriand
QC, Canada J7H 1M9

450 979-0667
info@lumifaro.com
www.lumifaro.com

CLIENT:
PROJECT:
DATE: