



HARDWIRE JUNCTION BOX WITH TRANSFORMER

UNDERCABINET LIGHTING

CL-HWB12-WH



PROJECT
FIXTURE TYPE
MODEL
LAMP
CONTACT/TELEPHONE

Specifications for Hardwire Box

Description

One metal housing hardwire box, painted in white. Has a 60W electronic transformer and one 10 foot long wiring harness that can connect up to 3 pucks. Available in White with white wiring harness.

Description

- Comes with an option to hardwire up to three pucks directly to the hardwire box or to connect two or three pucks using the 10 foot wiring harness. [Fig. 1, Fig 3 & Fig. 4]
- Two of the 2 in 2 out terminals built inside of the hardwire box are suitable for #10 to #18 AWG wires.
- Hardwire box comes with one 60W class II transformer with built-in short circuit protection.
- Push-in Quick-connectors for quick wiring are suitable for #20 to #12 AWG solid wires.
- 8 electric pry-outs - 7/8" for easy wiring connection.
- Mounting hardware included - plastic cable ties and plastic clips with nails.

Dimmer

Yes, for use with electronic low-voltage dimmers

Input/Output

- 120V AC 60Hz/12V AC

Dimensions & Ordering Guide

Model	Colour
CL-HWB12-WH	White box with white wiring harness.

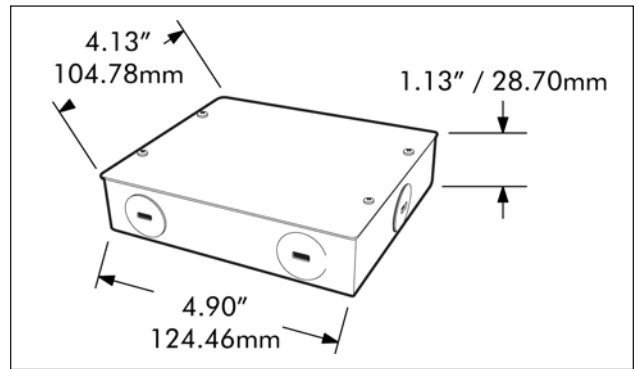

All dimensions are in inches / millimeters

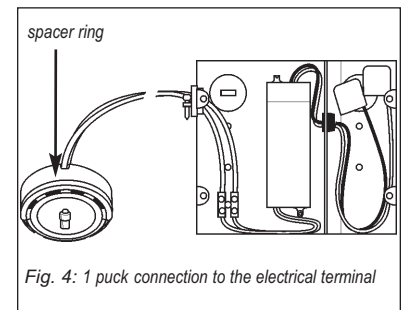
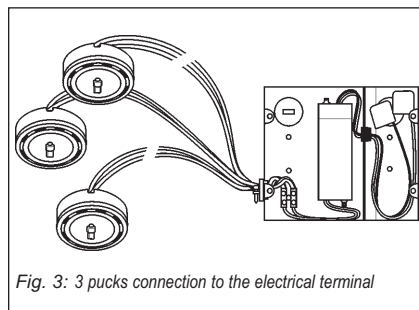
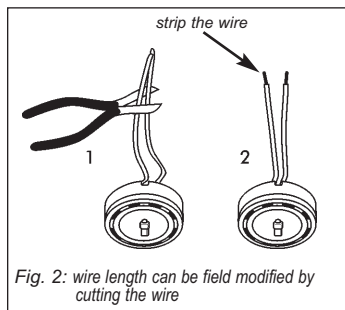
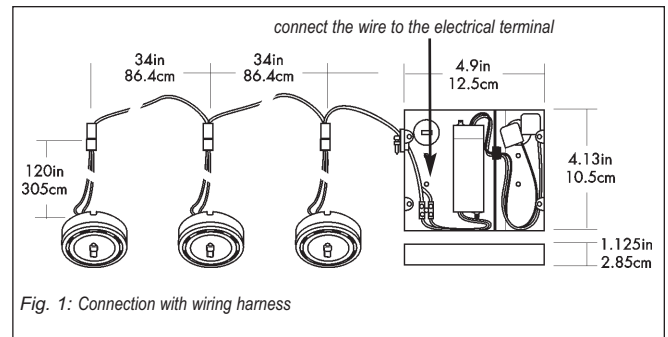

Listings



LITELINE CORPORATION

8 Abacus Road, Brampton, Ontario, Canada L6T 5B7
 Tel: 416-996-1856 • Fax: 905-794-1990 / 1-888-738-9736
 E-mail: sales@liteline.com • Website: www.liteline.com

Product specifications subject to change without notice.