

Job Information		
Project Name		Type
Location		
Quantity		Date
Contact/Phone		
Notes		

# WL-VBE

Vapour Barrier Extender for Wall Lights  
Recessed Lighting

## Features

### General Features

The body is constructed from a membrane with flat flange all around to better enclose fixture from insulation. Rated max. 90°C.



### Description

Vapour barrier extender for use with DazzLED LED wall lights in insulated exterior wall applications to prevent moisture from entering into the fixture.

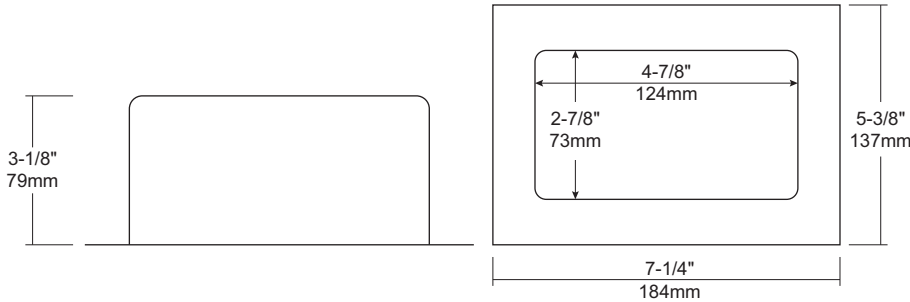

**Notes:** For additional options please consult your Liteline representative. Due to our continued efforts to improve our products, product specifications are subject to change without notice.

## Ordering Guide



### WL-VBE

Vapour barrier extender for use with wall lights.

