



CEILING MOUNTED
SECURITY LIGHTING
INDOOR SMALL SIZE
Multi Tap
CMS-070-HPS-MT

PROJECT	Canadalite.com
FIXTURE TYPE	
MODEL	
LAMP	
CONTACT/TELEPHONE	1(888)887-7038

Specifications

Description

Indoor ceiling mounted small size security light, CUL listed for damp location. Designed for garage or indoor applications. 70W High Pressure Sodium Multi Tap (120/277/347V) configuration.

Lamp Wattage / Type

- Supplied with 70W clear medium base, ED17 HPS.

Features

- Designed for commercial applications.
- Fast and easy mounting to reduce installation cost.
- UV stabilized polycarbonate diffuser gives strength against breakage.
- Powder coated steel reflector provides low glare visibility.

Housing

- Die-cast aluminum housing designed for maximum heat dissipation.
- Low profile design to give maximum underside clearance
- Electrostatic powder finish in bronze and white.

Electrical

- HID ballast, class "H" insulation, available as normal power factor with Multi Tap input configuration 120/277/347V.
- Capable of starting from -20°C.
- Prewired for 347V.

Dimensions & Ordering Guide

Model

- CMS-070-HPS-MT-BR
- CMS-070-HPS-MT-WH

Description

- Bronze Housing
- White Housing
- 70W Multi Tap 120/277/347V MH ceiling mount security light designed for indoor damp location applications

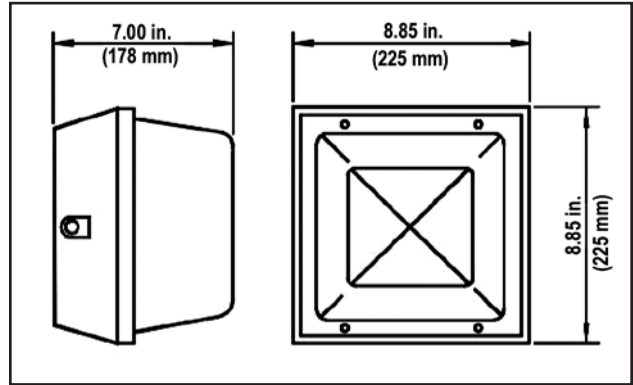

Listings



LITELINE CORPORATION

8 Abacus Road, Brampton, Ontario, Canada L6T 5B7
Tel: 416-996-1856 • Fax: 905-794-1990 / 1-888-738-9736
E-mail: sales@liteline.com • Website: www.liteline.com

Product specifications subject to change without notice.

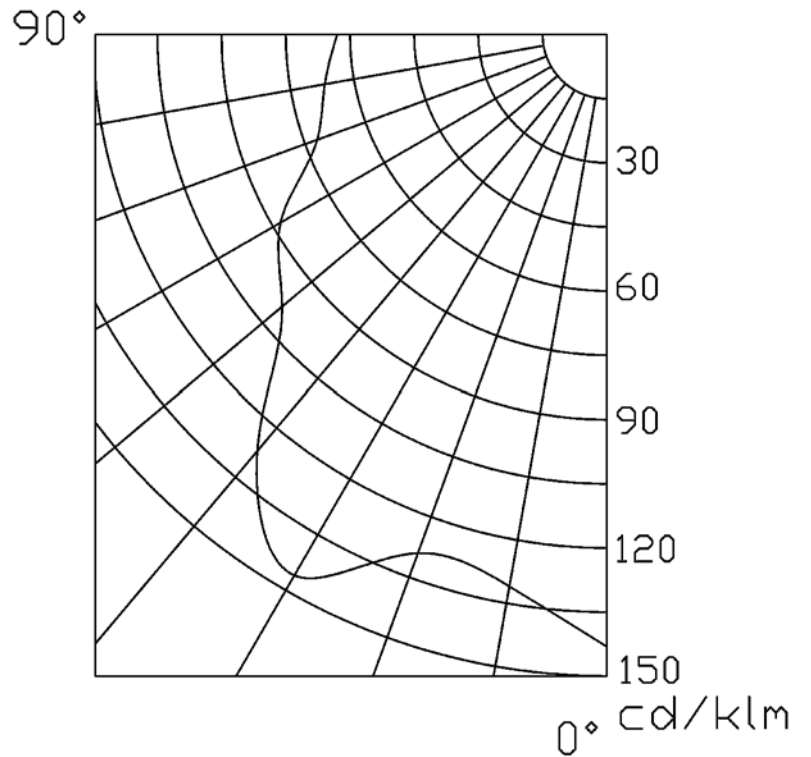

Listings



LITELINE CORPORATION
8 Abacus Road, Brampton, Ontario, Canada L6T 5B7
Tel: 416-996-1856 • Fax: 905-794-1990 / 1-888-738-9736
E-mail: sales@liteline.com • Website: www.liteline.com

Product specifications subject to change without notice.