

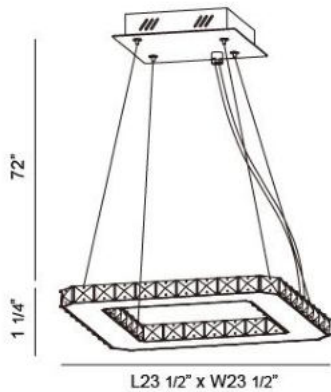

Sleek, modern and clean architectural designs infused with old world crystal and powered by cutting edge LED lighting give this collection us in every design space.



## CRONOS , LARGE SQUARE LED PENDANT

### Product Specifications

Collection:	Illuminations
Item No.:	20399-016
Height:	1.25"
Chain / Cord Length:	72"
Width:	23.5"
Length:	23.5"
Est. Shipping Weight:	21.60 lbs
No. of Bulbs:	28 Inc.
Bulb Wattage:	1 watts
Bulb Type:	LED <sup>TM</sup>
Bulb Base:	LED
Bulb Voltage:	120 volts

### Options Available

ITEM CODE	FINISH	SHADE
20399-016	chrome	clear crystal

### Colour / Shades Available

FINISH	SHADE
chrome	<input type="radio"/> clear crystal

### Project Information

Job Name: Canadalite.com Date: \_\_\_\_\_ Type: \_\_\_\_\_  
 Comments: 534 Hood Road,Markham ON L3R 3K9 Email:info@canadalite.com