



## TOBIAS , 3-LIGHT TABLE LAMP W/RGB LED

### Product Specifications

Collection:	Illuminations
Item No.:	19491-011
Height:	27.75"
Width:	15.75"
Length:	15.75"
Est. Shipping Weight:	25.74 lbs
No. of Bulbs:	3 Inc.
Bulb Wattage:	60 watts
Bulb Type:	A19 
Bulb Base:	E26
Bulb Voltage:	120 volts

### Options Available

ITEM CODE	FINISH	SHADE
19491-011	chrome	white

### Colour / Shades Available

FINISH	SHADE
chrome 	white

The Tobias series invokes a neo-classic elegance in its innovative inception. A shimmering square shade is the ideal complementary feature for a linear tapestry of crystal beading. LED lights favour a brilliant and stimulating emanation. The glossed chrome base provides a reflective backdrop that allows the impressive light to diffuse evenly.

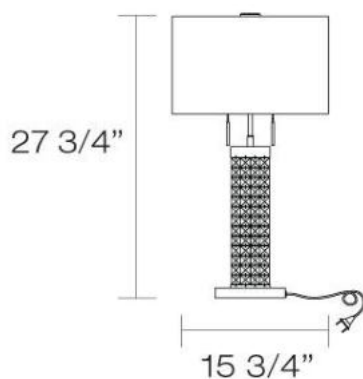

### Project Information

Job Name: \_\_\_\_\_ Date: \_\_\_\_\_ Type: \_\_\_\_\_  
 Comments: \_\_\_\_\_