

ULTRASAVE

UT332347H



| | | | |
|-------------------------|---------------|------------------------------|---------------|
| Ballast Type: | Electronic | Starting Method: | Instant Start |
| Lamp Connection: | Parallel | Input Voltage: | 347 |
| Input Frequency: | 50/60 Hz | Sound Rating: | A |
| Remote Mounting: | 18 ft Maximum | Warranty: | Five Years |
| EOL Protection: | No | Max Case Temperature: | 70°C |

ELECTRICAL SPECIFICATIONS

| Lamp Type | # of Lamps | Rated Lamp Watts | Min. Start Temp. (°F/°C) | Input Current (Amps) | Input Power (Watts) | Ballast Factor | Max THD % | Power Factor | Max L.C.C.F. | B.E.F |
|-----------|------------|------------------|--------------------------|----------------------|---------------------|----------------|-----------|--------------|--------------|-------|
| F32T8 | 3 | 32 | 0 / -18 | 0.32 | 110 | 1.18 | 10 | 0.99 | 1.70 | 1.07 |
| F25T8 | | 25 | | 0.25 | 85 | 1.20 | | | | 1.41 |

REGULATORY COMPLIANCE

- Meets ANSI Standard C82.11
- Meets ANSI Standard C62.41
- Meets FCC Part 18 Class A for EMI & RFI (Non-Consumer Limits)

- No PCB's
- cULus Listed (Class P, Type 1 Outdoor, Type HL)
- RoHS Compliant



ULTRASAVE LIGHTING LTD.

12-140 AMBER STREET, MARKHAM, ON L3R 3J8

TEL 905.940.0888

FAX 905.940.0338

WWW.ULTRASAVE.CA

Data published here is based on the result of a test under a controlled environment. Actual performance can vary depending on operating conditions. Specifications are subject to change without notice. A0509USL

PHYSICAL CHARACTERISTICS

WIRING DIAGRAM

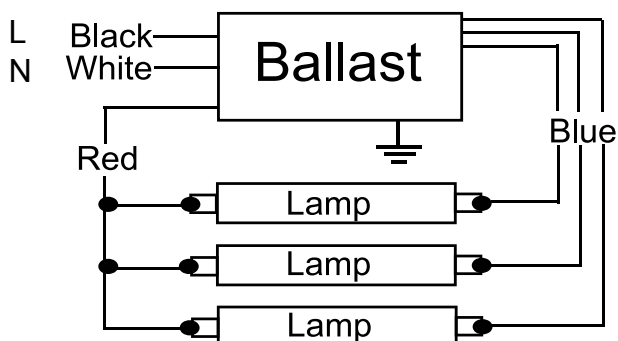

LEAD LENGTH

| Wire | in |
|-------|----|
| Black | 19 |
| White | 19 |
| Blue | 31 |
| Red | 47 |

CASE DIMENSIONS

| | |
|--------------|-------|
| Overall (L) | 9.50" |
| Width (W) | 1.72" |
| Height (H) | 1.18" |
| Mounting (M) | 8.90" |

HOT SPOT LOCATION

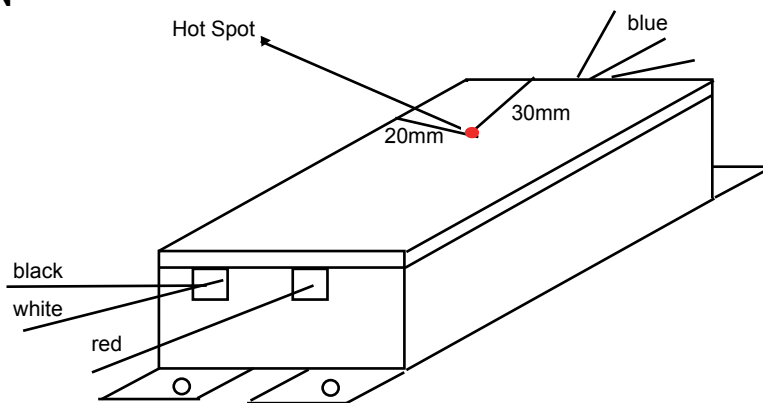

ORDERING INFORMATION

| Model # | Carton Weight | Carton Dimensions LxWxH | Carton Quantity | Skid Quantity | Bulk Quantity |
|-----------|---------------|-------------------------|-----------------|---------------|---------------|
| UT332347H | 29.80 lbs | 11.02" x 10.63" x 9.06" | 20 | 1000 | 1104 |

ULTRASAVE LIGHTING LTD.

12-140 AMBER STREET, MARKHAM, ON L3R 3J8

TEL 905.940.0888

FAX 905.940.0338

WWW.ULTRASAVE.CA

Data published here is based on the result of a test under a controlled environment. Actual performance can vary depending on operating conditions. Specifications are subject to change without notice. A0509USL