

ER221347MHT



Ballast Type:	Electronic	Starting Method:	Programmed Start
Lamp Connection:	Series	Input Voltage:	277 to 347
Input Frequency:	50/60 Hz	Sound Rating:	A
Remote Mounting:	18 ft Maximum	Warranty:	Five Years
End-of-Life Protection:	Yes	Max. Case Temperature:	90°C

ELECTRICAL SPECIFICATIONS

Lamp Type	# of Lamps	Rated Lamp Watts	Min. Start Temp. (°F/°C)	Input Current (Amps)	Input Power (Watts)	Ballast Factor	Max THD %	Power Factor	Max. L.C.C.F.	B.E.F
14W T5	1	14	-20 / -29	0.07 / 0.05	18	1.00	10	0.99	1.50	5.56
	2			0.13 / 0.10	34					2.94
21W T5	1	21		0.10 / 0.07	25					4.00
	2			0.18 / 0.15	50					2.00

REGULATORY COMPLIANCE

- Meets ANSI Standard C82.11
- Meets ANSI Standard C62.41
- Meets FCC Part 18 Class A for EMI & RFI (Non-Consumer Limits)

- No PCB's
- cULus Listed (Class P, Type 1 Outdoor, Type HL)
- RoHS Compliant



ULTRASAVE LIGHTING LTD.

12-140 AMBER STREET, MARKHAM, ON L3R 3J8

TEL 905.940.0888

FAX 905.940.0338

WWW.ULTRASAVE.CA

PHYSICAL CHARACTERISTICS

WIRING DIAGRAM

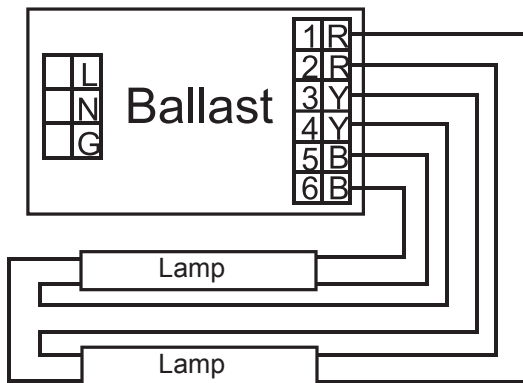
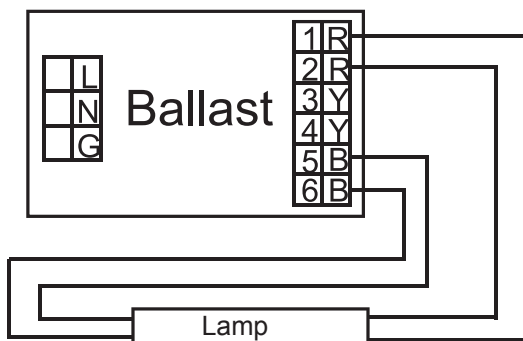

CASE DIMENSIONS

Overall (L)	11.50"
Width (W)	1.32"
Height (H)	1.05"
Mounting (M)	11.25"

ORDERING INFORMATION

Model #	Carton Weight	Carton Dimensions LxWxH	Carton Quantity	Skid Quantity
ER221347MHT	21.00 lbs	13.98" x 8.66" x 6.30"	20	1000

ULTRASAVE LIGHTING LTD.

12-140 AMBER STREET, MARKHAM, ON L3R 3J8

TEL 905.940.0888

FAX 905.940.0338

WWW.ULTRASAVE.CA