

MB2110120HO



Ballast Type:	Magnetic	Starting Method:	Rapid Start
Lamp Connection:	Series	Input Voltage:	120
Input Frequency:	60 Hz	Sound Rating:	C
Remote Mounting:	18 ft Maximum	Warranty:	Three Years
End-of-Life Protection:	No	Max. Case Temperature:	90°C

ELECTRICAL SPECIFICATIONS

Lamp Type	# of Lamps	Rated Lamp Watts	Min. Start Temp. (°F/°C)	Input Current (Amps)	Input Power (Watts)	Ballast Factor	Max THD %	Power Factor	Max. L.C.C.F.	B.E.F
F72T12/HO	2	85	-20 / -29	1.60	193	0.95	15	0.98	1.80	0.49
F96T12/HO		110	-20 / -29	2.00	232	0.93	15		1.70	0.40
F96T12/HO/ES		95	60 / 16	1.70	203	0.91	20		1.80	0.45

REGULATORY COMPLIANCE

- Meets ANSI Standard C82.11
- Meets FCC Part 18 Class A for EMI & RFI (Non-Consumer Limits)
- No PCB's
- cULus Listed (Class P, Type 1 Outdoor, Type HL)



ULTRASAVE LIGHTING LTD.

12-140 AMBER STREET, MARKHAM, ON L3R 3J8 TEL 905.940.0888 FAX 905.940.0338 WWW.ULTRASAVE.CA

Data published here is based on the result of a test under a controlled environment. Actual performance can vary depending on operating conditions. Specifications are subject to change without notice. H1109USL

PHYSICAL CHARACTERISTICS

WIRING DIAGRAM

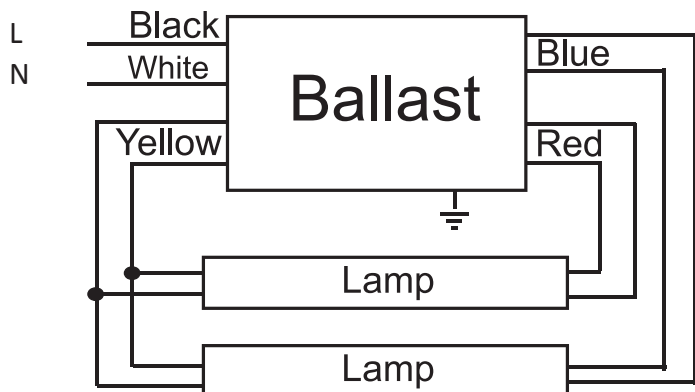

LEAD LENGTH

Wire	in
Black	22
White	22
Blue	46
Red	46
Yellow	70

CASE DIMENSIONS

Overall (L)	11.73"
Width (W)	3.19"
Height (H)	2.63"
Mounting (M)	11.14"

ORDERING INFORMATION

Model #	Carton Weight	Carton Dimensions LxWxH	Carton Quantity	Skid Quantity
MB2110120HO	37.30 lbs	12.44" x 8.15" x 6.30"	4	180

ULTRASAVE LIGHTING LTD.

12-140 AMBER STREET, MARKHAM, ON L3R 3J8

TEL 905.940.0888

FAX 905.940.0338

WWW.ULTRASAVE.CA